

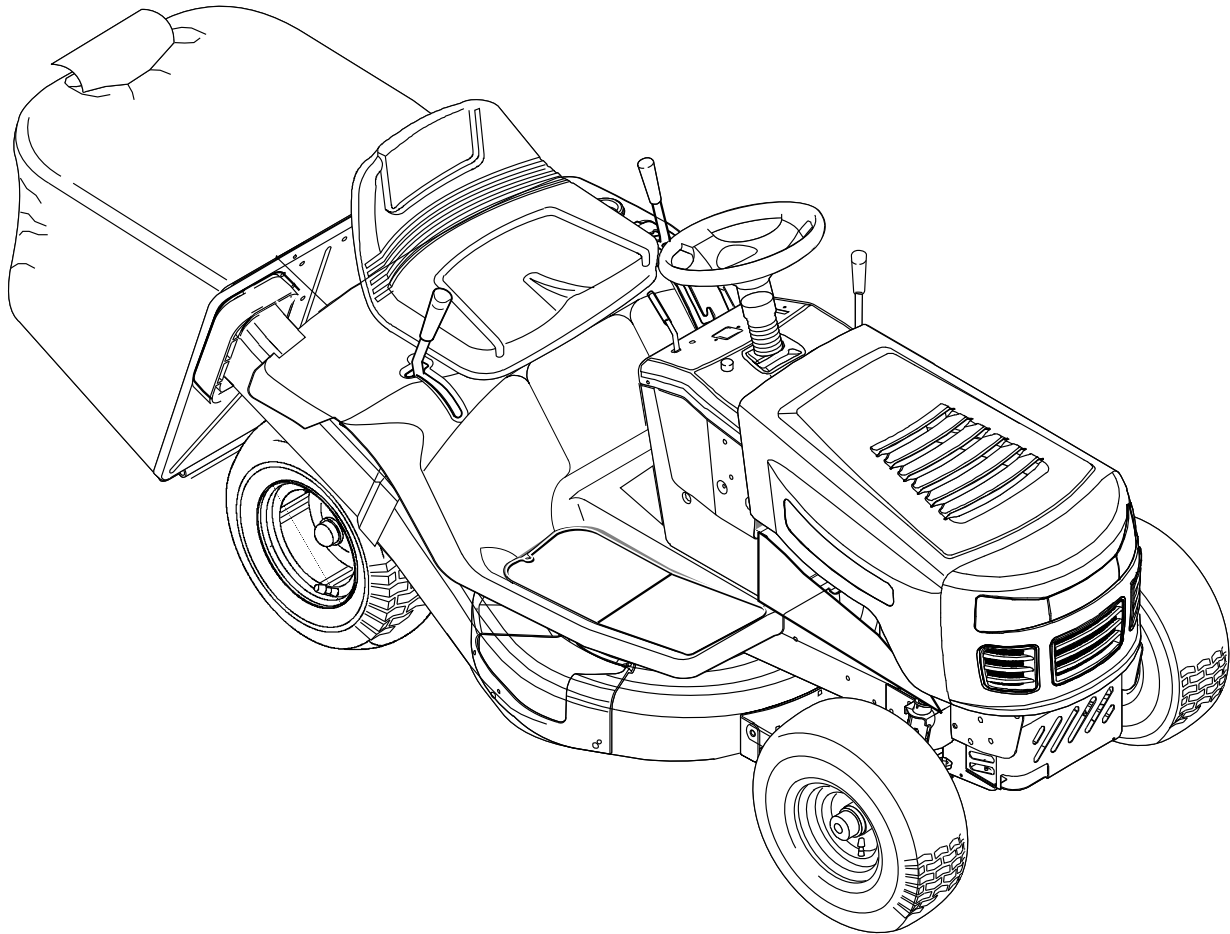

Parts List

Model
7800523



1742361
Revision -
Rev. Date 02/2009

Not for
Reproduction

PRODUCT COMPONENTS	PAGES
Chassis & Hood	4
Steering	8
Motion Drive	12
Mower Housing	16
Mower Housing Suspension	20
Decals	24
Electrical System	26
Engine Mount	28
Grass Bagger	30
Torque Specification Chart	Inside Back Cover

Not for
Reproduction

Chassis & Hood

NOTE: Unless noted otherwise,
use the standard hardware torque
specification chart.

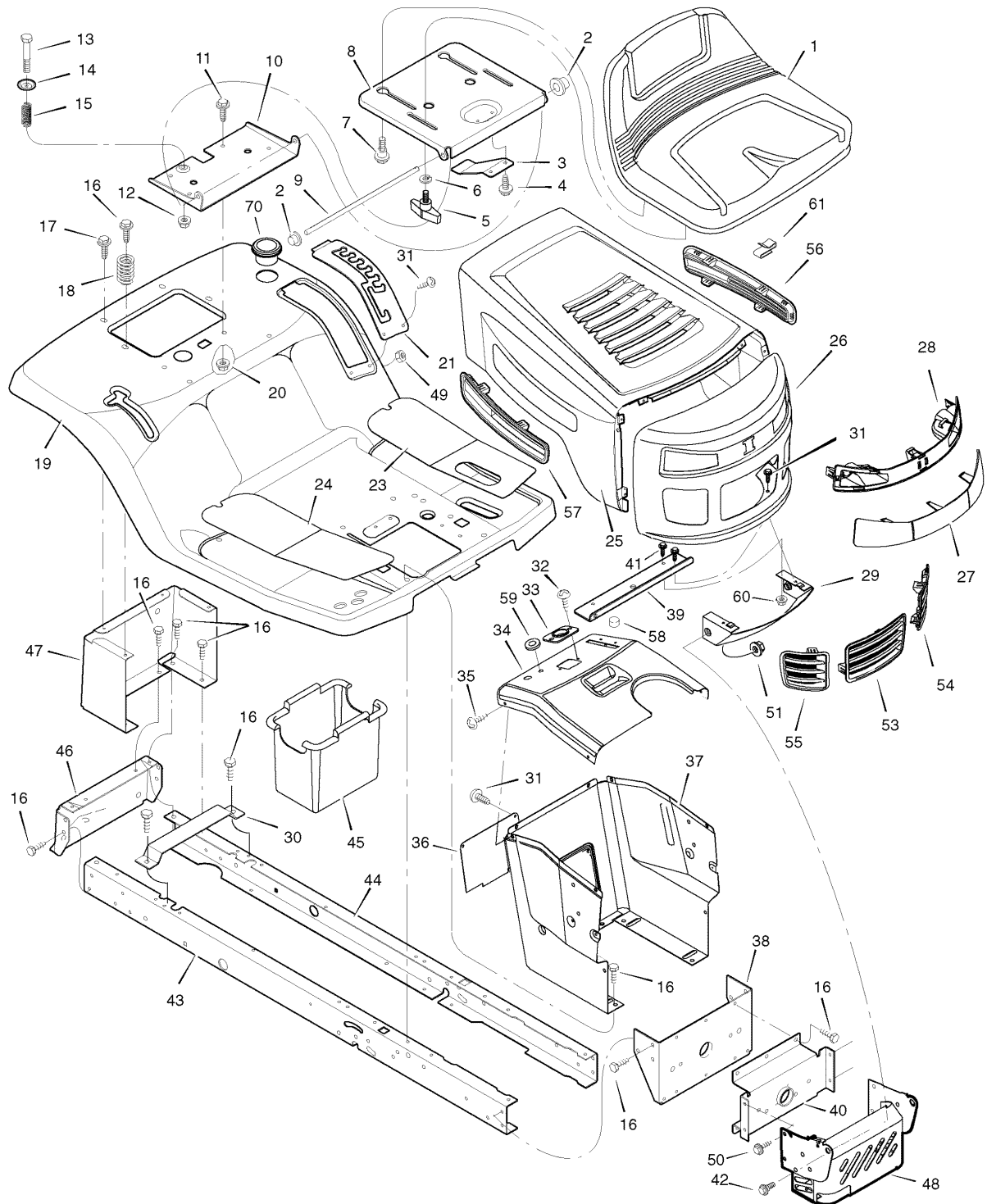

The above parts group applies to the following Mfg. Nos.:
7800523 - 312006x51A

Chassis & Hood

REF NO	PART NO.	DESCRIPTION
1	7101860YP	SEAT
2	028X23MA	CAP, Push On
3	094057MA	SPRING
4	26X229MA	SCREW
5	1001054MA	BOLT, Wing
6	017X47MA	WASHER
7	009X56MA	BOLT, Shoulder
8	7300875ZMA	SUPPORT, Seat
9	094156ZMA	ROD, Pivot
10	7300794ZMA	BRACKET, Pivot
11	001X45MA	BOLT
12	015X89MA	NUT
13	009X55MA	BOLT, Shoulder
14	094155ZMA	WASHER
15	164X31MA	SPRING
16	26X249MA	SCREW
17	26X263MA	SCREW
18	164X30MA	SPRING
19	7300843ZMA	DECK, Seat
20	15X123MA	NUT
21	7300839ZMA	PLATE, Lift
23	094999MA	MAT, Left
24	094998MA	MAT, Right
25	7300786ZMA	HOOD, WM1
26	7300778TMA	GRILLE
27	1001806MA	LENS
28	1001805MA	HOUSING, Headlamp
29	1740530TMA	BRACKET, Lower Pivot
30	7300741ZMA	SUPPORT, Battery
31	26X270MA	SCREW
32	26X238MA	SCREW
33	1001491MA	BEARING, Steering
34	7300774TMA	DASH
35	26X201MA	SCREW
36	7300750TMA	PANEL, Access
37	7300872TMA	SUPPORT, Dash
38	7300751ZMA	BRACKET, Rear Hanger
39	1740529TMA	BRACKET, Support
40	7300742ZMA	AXLE, Hanger
41	26X263MA	SCREW
42	009X58MA	BOLT, Shoulder
43	7300870ZMA	FRAME, Right
44	7300869ZMA	FRAME, Left

Footnotes

The above parts group applies to the following Mfg. Nos.:

7800523 - 312006x51A

Chassis & Hood

REF NO	PART NO.	DESCRIPTION
45	690424MA	CONTAINER, Battery
46	7300864ZMA	PLATE, Hitch
47	7300832ZMA	PANEL, Rear
48	1740501E701MA	SHIELD, Heat
49	015X81MA	NUT
50	26X277MA	SCREW
51	15X124MA	NUT
53	1741762MA	INSERT, Center Grille
54	1741763MA	INSERT, Left Grille
55	1741764MA	INSERT, Right Grille
56	1741760MA	INSERT, Left Hood
57	1741761MA	INSERT, Right Hood
58	094376MA	BUMPER
59	1001755MA	GROMMET, Parking Brake
60	015X82MA	NUT
61	028X83MA	S-CLIP, Black
70	1741770MA	HOLDER, Beverage, Gray
--	1002050MA	PARTS BAG, Assembly
--	1742360	MANUAL, Instruction Book
--	1742361	MANUAL, Parts List

Not for
Reproduction

Footnotes

The above parts group applies to the following Mfg. Nos.:

7800523 - 312006x51A

Steering

**NOTE: Unless noted otherwise,
use the standard hardware torque
specification chart.**

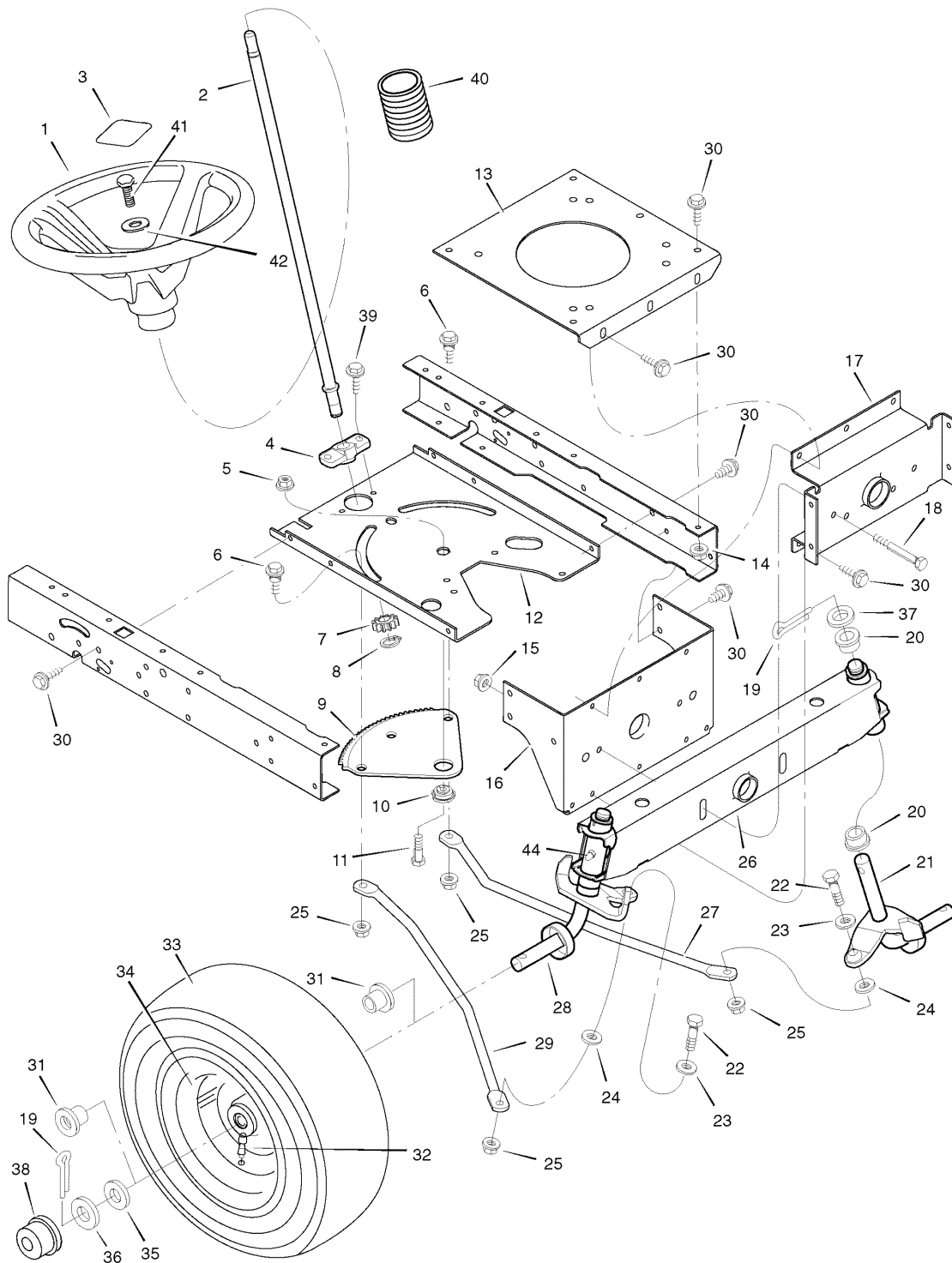

The above parts group applies to the following Mfg. Nos.:
7800523 - 312006x51A

Steering

REF NO	PART NO.	DESCRIPTION
1	1001980MA	WHEEL, Steering
2	690625MA	POST, Steering
3	1001982MA	COVER, Steering Wheel
4	094124MA	BEARING (Included with Ref. No. 2)
5	7091601SM	NUT, Flange **
6	009X57MA	BOLT, Shoulder
7	1001893MA	GEAR, Pinion (Included with Ref. No. 2)
8	011X25MA	RING, Snap **
9	094121MA	GEAR, Sector
10	094123MA	BEARING
11	7027168SM	CAP SCREW, Hex Head, 5/16C X1 GR5 YZ
12	7300867ZMA	PLATE, Steering
13	7300863ZMA	PLATE, Engine
14	015X88MA	NUT, Flange
15	15X118MA	NUT, Flange
16	7300751ZMA	BRACKET, Hanger
17	7300742ZMA	AXLE, Hanger
18	01X146MA	BOLT
19	030X49MA	PIN, Cotter
20	690150MA	BEARING
21	1001299E701MA	SPINDLE ASSEMBLY, Left
22	01X111MA	BOLT
23	710083MA	WASHER
24	017X53MA	WASHER
25	7091619SM	NUT, Flange
26	7400246ZYP	AXLE ASSEMBLY
27	7101805ZMA	DRAG LINK, Left
28	1001298E701MA	SPINDLE ASSEMBLY, Right
29	7101806ZMA	DRAG LINK, Right
30	26X249MA	SCREW
31	091334MA	BEARING, Wheel
32	024373MA	STEM, Valve
33	-----	TIRE *
--	407924MA	TUBE
34	7101866MA	WHEEL & TIRE ASSEMBLY
35	17X195MA	WASHER
36	17X192MA	WASHER
37	1733001SM	WASHER
38	094618MA	HUB CAP
39	26X267MA	SCREW
40	092059MA	BELLOWS
41	0025X3MA	SCREW, Hex
42	17X146MA	WASHER

Footnotes

Note * When you order a tire, make sure to give the brand name of the tire so that the tread pattern on the tire will match.

Note** This part included when ordering Ref. No. 2.

The above parts group applies to the following Mfg. Nos.:

7800523 - 312006x51A

Steering

**NOTE: Unless noted otherwise,
use the standard hardware torque
specification chart.**

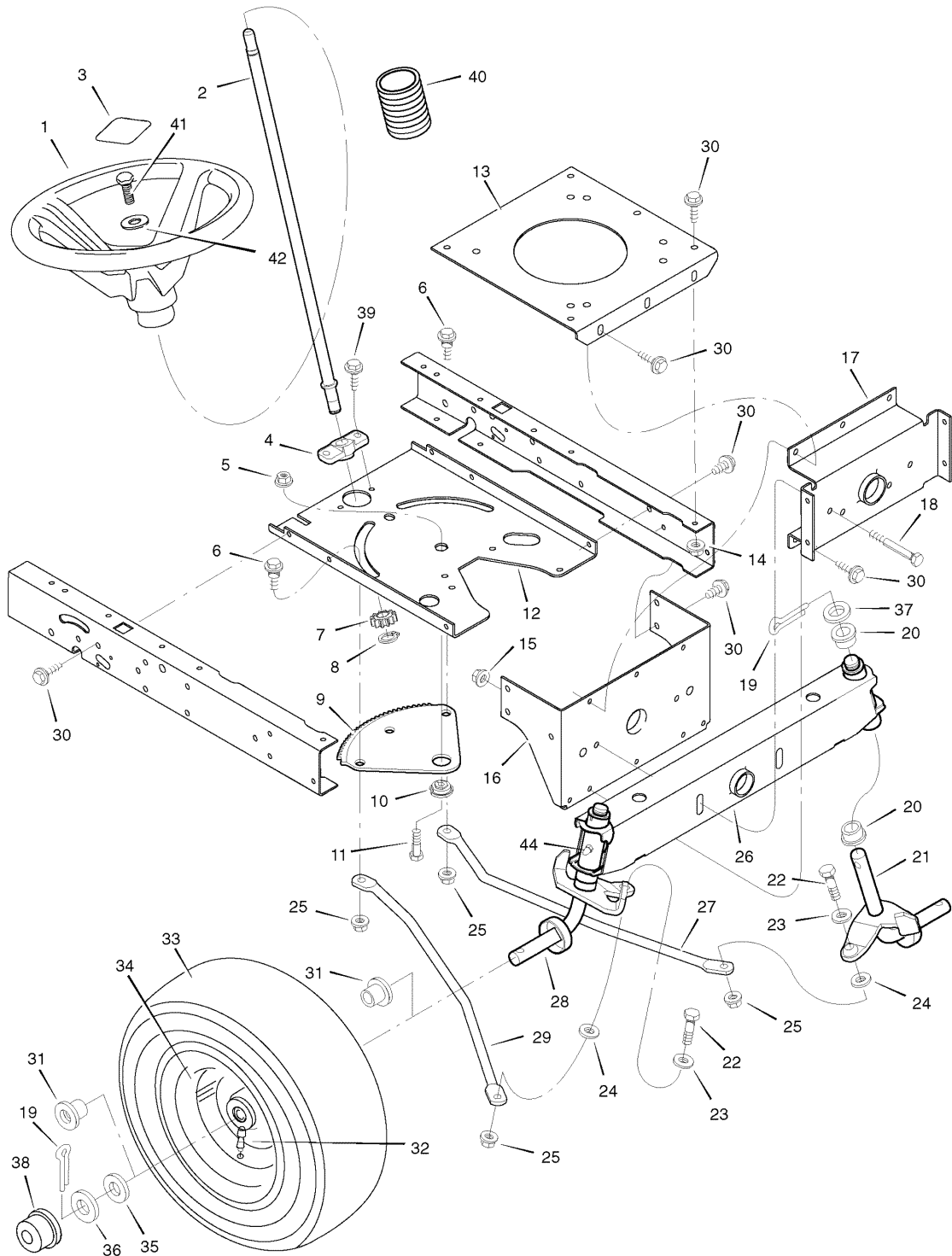

The above parts group applies to the following Mfg. Nos.:
7800523 - 312006x51A

Steering

REF NO	PART NO.	DESCRIPTION
44	092530MA	FITTING, Grease

Not for
Reproduction

Footnotes

Note * When you order a tire, make sure to give the brand name of the tire so that the tread pattern on the tire will match.

Note** This part included when ordering Ref. No. 2.

The above parts group applies to the following Mfg. Nos.:

7800523 - 312006x51A

Motion Drive

NOTE: Unless noted otherwise,
use the standard hardware torque
specification chart.

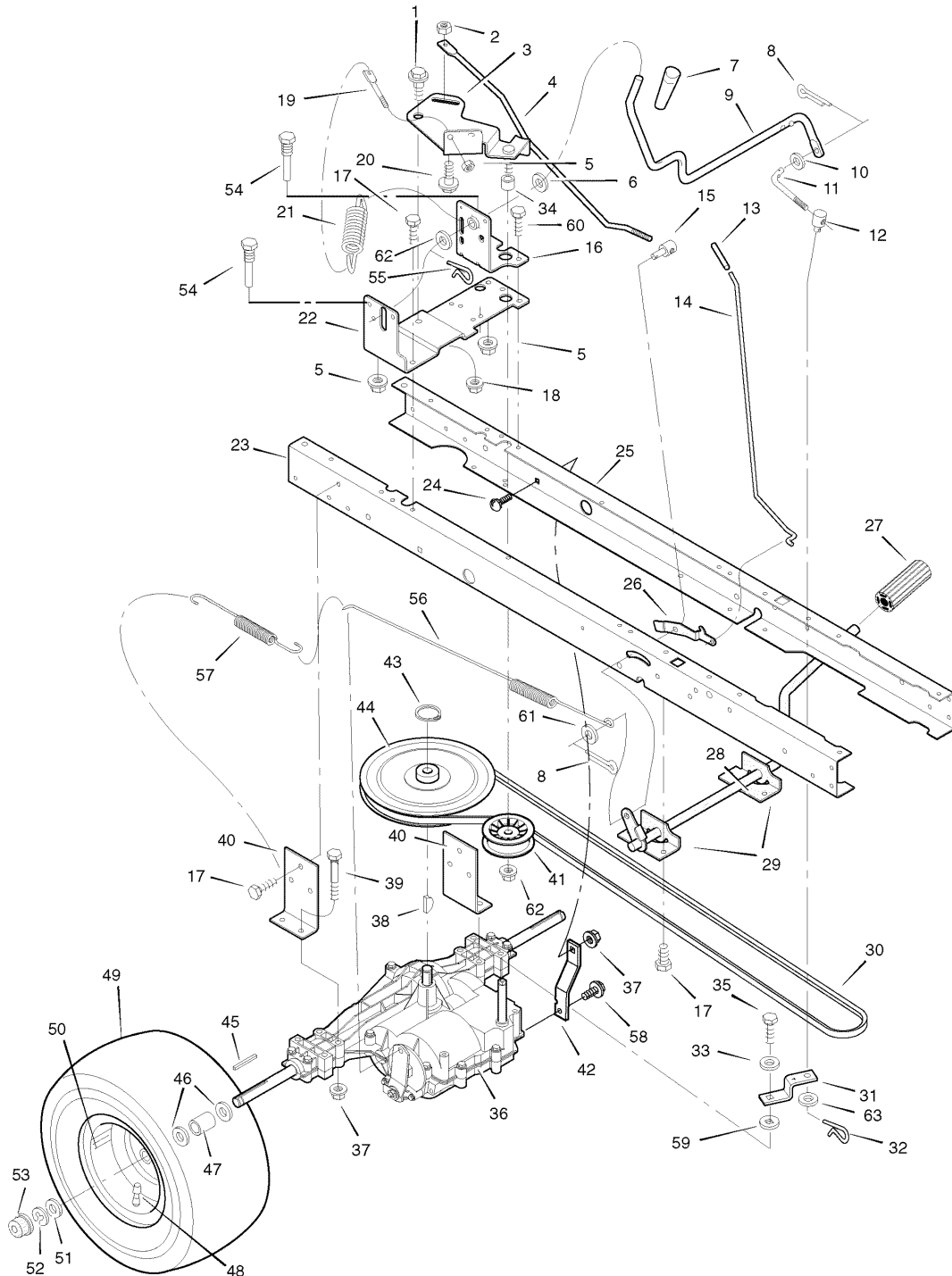

The above parts group applies to the following Mfg. Nos.:

7800523 - 312006x51A

Motion Drive

REF NO	PART NO.	DESCRIPTION
1	009X39MA	BOLT, Shoulder
2	015X89MA	NUT, Hex
3	690273MA	ARM, Idler
4	094041ZMA	ROD, Clutch
5	7091601SM	NUT
6	17X102MA	WASHER
7	1741756MA	GRIP
8	030X20MA	PIN, Cotter
9	094043ZMA	LEVER, Shift
10	017X47MA	WASHER
11	094044ZMA	LINK, Shift
12	021920ZMA	NUT, Adjuster
13	1741757MA	GRIP
14	1001245ZMA	ROD, Parking Brake
15	094815ZMA	NUT, Adjuster
16	1001303ZMA	BRACKET, Shift Pivot
17	26X249MA	SCREW
18	015X84MA	NUT
19	094042ZMA	MOUNT, Stud Spring
20	009X54MA	BOLT, Shoulder
21	165X116MA	SPRING, Extension
22	7300824ZMA	BRACKET, Right Shifter
23	1001928E701MA	FRAME, Right
24	002X53MA	BOLT, Carriage
25	1001927E701MA	FRAME, Left
26	094045ZMA	LATCH, Parking Brake
27	021544MA	PEDAL
28	7400256ZMA	LEVER, Brake/Clutch
29	1001117E701MA	BRACKET, Pedal
30	037X87MA	BELT, Motion Drive
31	094031ZMA	YOKE, Shift
32	0031X6MA	PIN, Hair
33	017X38MA	WASHER
34	690369MA	SPACER
35	06X105MA	BOLT
36	-----	TRANSAXLE **
37	015X88MA	NUT
38	020697MA	KEY, Woodruff
39	01X155MA	BOLT
40	7300769ZMA	BRACKET, Transaxle
41	690409MA	PULLEY
42	7300845ZMA	BRACKET, Torque Strap, LH
43	0011X7MA	RING RETAINER

Footnotes

Note* When you order a tire, make sure to give the brand name of the tire so that the tread pattern on the tire will match.

Note** For Replacement Parts see the Transaxle manufacturer.

The above parts group applies to the following Mfg. Nos.:

7800523 - 312006x51A

Motion Drive

**NOTE: Unless noted otherwise,
use the standard hardware torque
specification chart.**

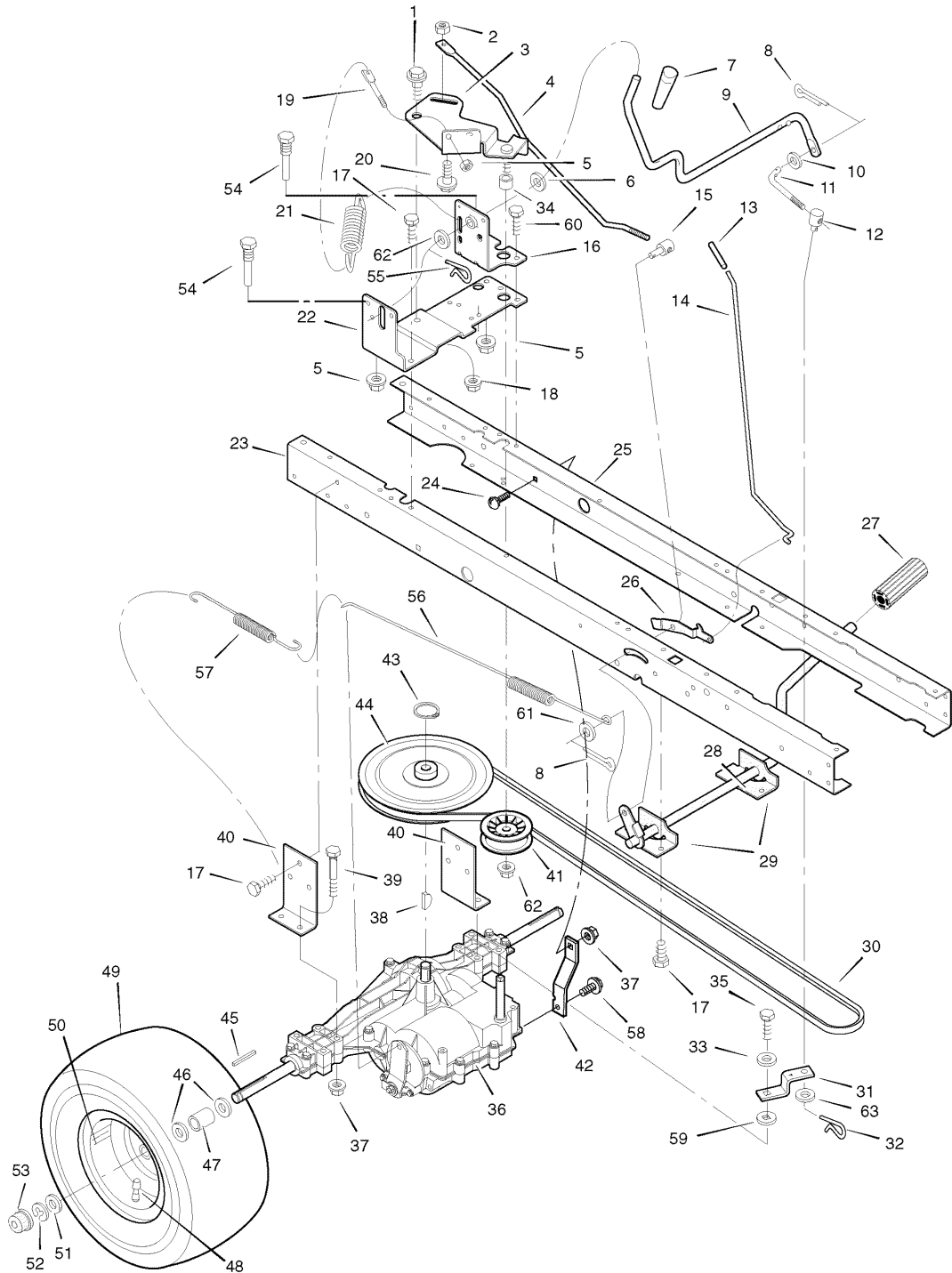

The above parts group applies to the following Mfg. Nos.:
7800523 - 312006x51A

Motion Drive

REF NO	PART NO.	DESCRIPTION
44	095094MA	PULLEY Drive
45	021553MA	KEY, Square
46	17X160MA	WASHER
47	690554ZMA	SPACER, Transaxle
48	024373MA	STEM, Valve
49	091923MA	TIRE *
--	407049MA	TUBE (Not Illustrated)
50	7101863MA	WHEEL & TIRE ASSEMBLY
51	17X195MA	WASHER
52	0011X3MA	E-Ring
53	094618MA	HUB CAP
54	093349MA	GUIDE, Belt
55	0031X4MA	PIN, Hair
56	165X141MA	SPRING, Extension
57	165X92MA	SPRING, Extension
58	26X216MA	SCREW
59	17X148MA	WASHER
60	26X267MA	SCREW
61	17X169MA	WASHER
62	015X98MA	NUT, Hex
63	017X53MA	WASHER

Not for
Reproduction

Footnotes

Note* When you order a tire, make sure to give the brand name of the tire so that the tread pattern on the tire will match.

Note** For Replacement Parts see the Transaxle manufacturer.

The above parts group applies to the following Mfg. Nos.:

7800523 - 312006x51A

Mower Housing

NOTE: Unless noted otherwise,
use the standard hardware torque
specification chart.

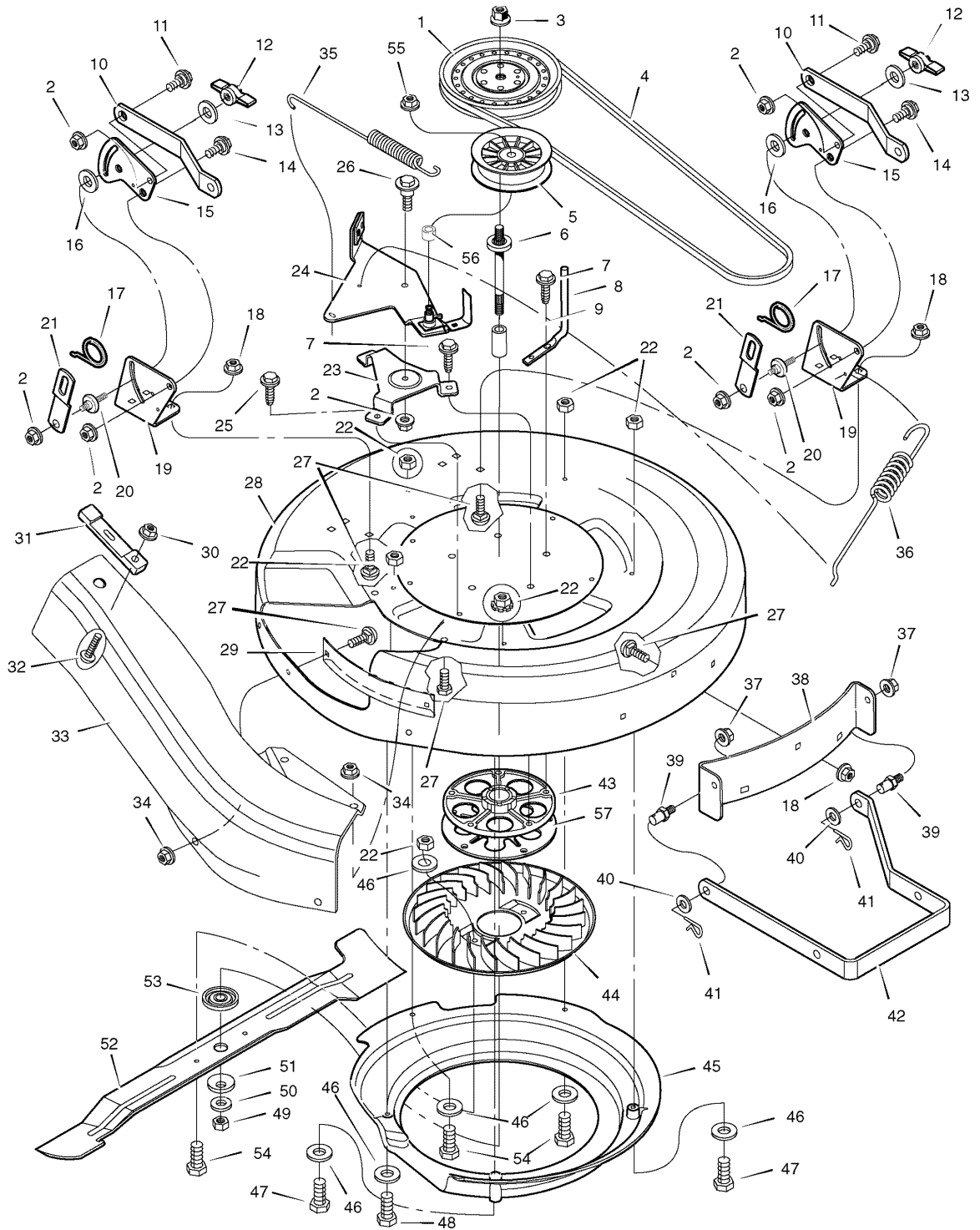

The above parts group applies to the following Mfg. Nos.:
7800523 - 312006x51A

Mower Housing

REF NO	PART NO.	DESCRIPTION
1	690432MA	PULLEY
2	015X84MA	NUT, Flange
3	15X140MA	NUT
4	037X74MA	BELT, Blade
5	091801MA	PULLEY, Idler
6	094129MA	MANDREL
7	025X23MA	SCREW
8	092424MA	GUIDE, Belt
9	094130MA	SPACER
10	7300826ZMA	BRACKET, Rear Suspension
11	009X52MA	BOLT, Shoulder
12	094068MA	KNOB
13	017X45MA	WASHER
14	009X51MA	BOLT, Shoulder
15	7300840ZMA	Plate, Suspension
16	094137MA	PAD, Friction
17	166X43MA	SPRING
18	015X79MA	NUT, Flange
19	7300737ZMA	BRACKET, Rear Deck
20	095194MA	PIN, Hanger
21	7300791ZMA	LINK, Lift
22	7090585MA	NUT
23	7300754ZMA	BRACKET, Idler Arm
24	1002076MA	ASSEMBLY, Idler Arm & Pad
25	26X249MA	SCREW
26	009X39MA	BOLT, Shoulder
27	002X64MA	BOLT, Carriage
28	7500695ZMA	HOUSING, Blade
29	7300730ZMA	BAFFLE, Deck, RH
30	015X88MA	NUT, Flange
31	054695MA	STRAP, Rubber
32	01X139MA	SCREW
33	690367MA	CHUTE
34	015X79MA	NUT
35	165X118MA	SPRING, PTO
36	165X140MA	SPRING, Extension
37	015X84MA	NUT, Flange
38	7300740ZMA	BRACKET, Front Deck
39	094067MA	PIN, Threaded Shoulder
40	017X91MA	WASHER
41	0031X4MA	PIN, Hair
42	7300784ZMA	HANGER, Front
43	1401275MA	HOUSING, Jackshaft

Footnotes

The above parts group applies to the following Mfg. Nos.:

7800523 - 312006x51A

Mower Housing

NOTE: Unless noted otherwise,
use the standard hardware torque
specification chart.

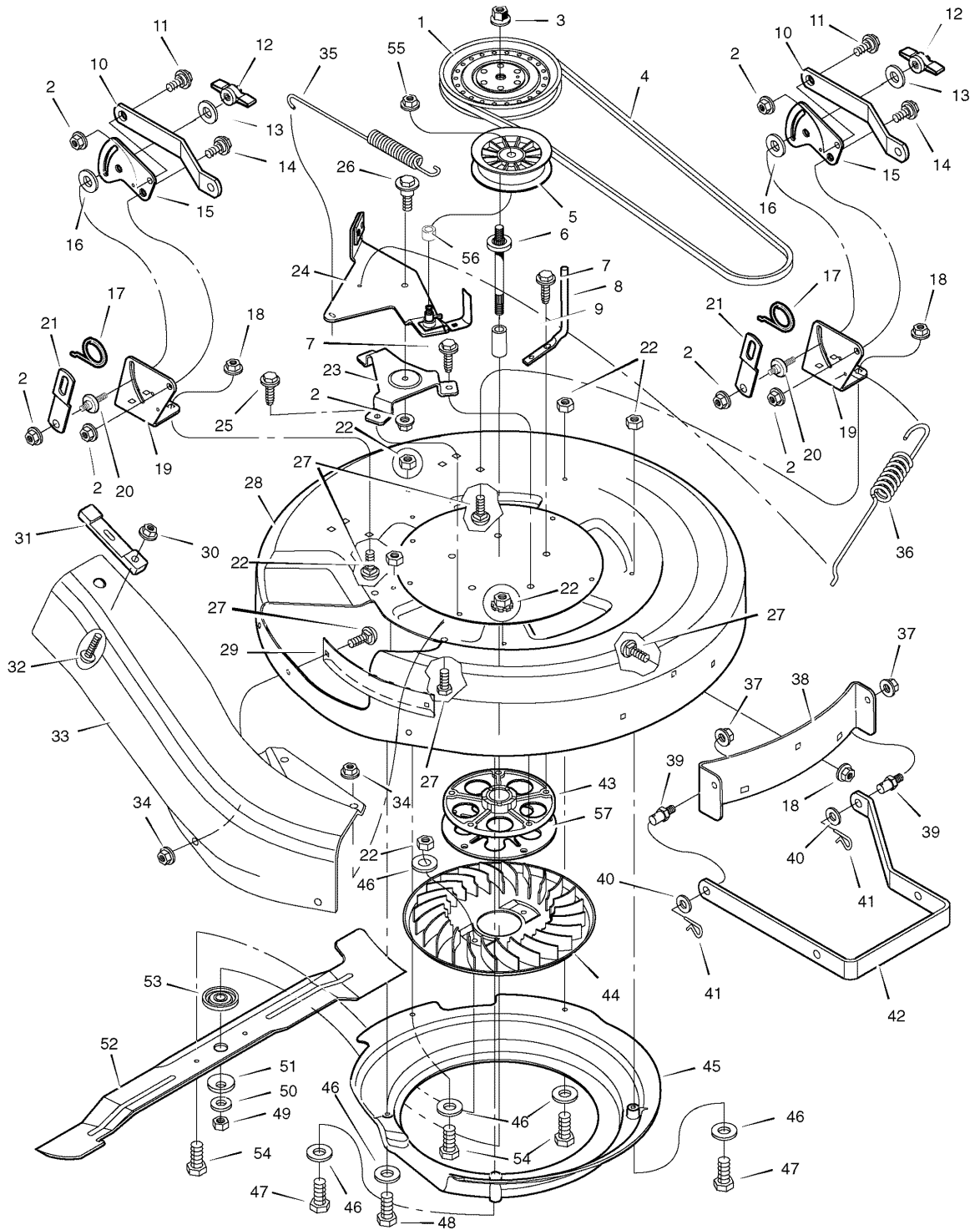

The above parts group applies to the following Mfg. Nos.:
7800523 - 312006x51A

Mower Housing

REF NO	PART NO.	DESCRIPTION
44	690359MA	FAN, Assist
45	1001237MA	HOUSING, Fan
46	017X37MA	WASHER
47	001X71MA	BOLT
48	01X106MA	BOLT
49	15X100MA	NUT
50	17X165MA	WASHER
51	17X166MA	WASHER, Belleville
52	1002068E701MA	BLADE
53	092466MA	ADAPTER, Blade
54	01X121MA	BOLT
55	015X98MA	NUT, Flange
56	690369MA	SPACER
57	7300836ZMA	PLATE, Jackshaft Support

Not for
Reproduction

Footnotes

The above parts group applies to the following Mfg. Nos.:

7800523 - 312006x51A

Mower Housing Suspension

NOTE: Unless noted otherwise,
use the standard hardware torque
specification chart.

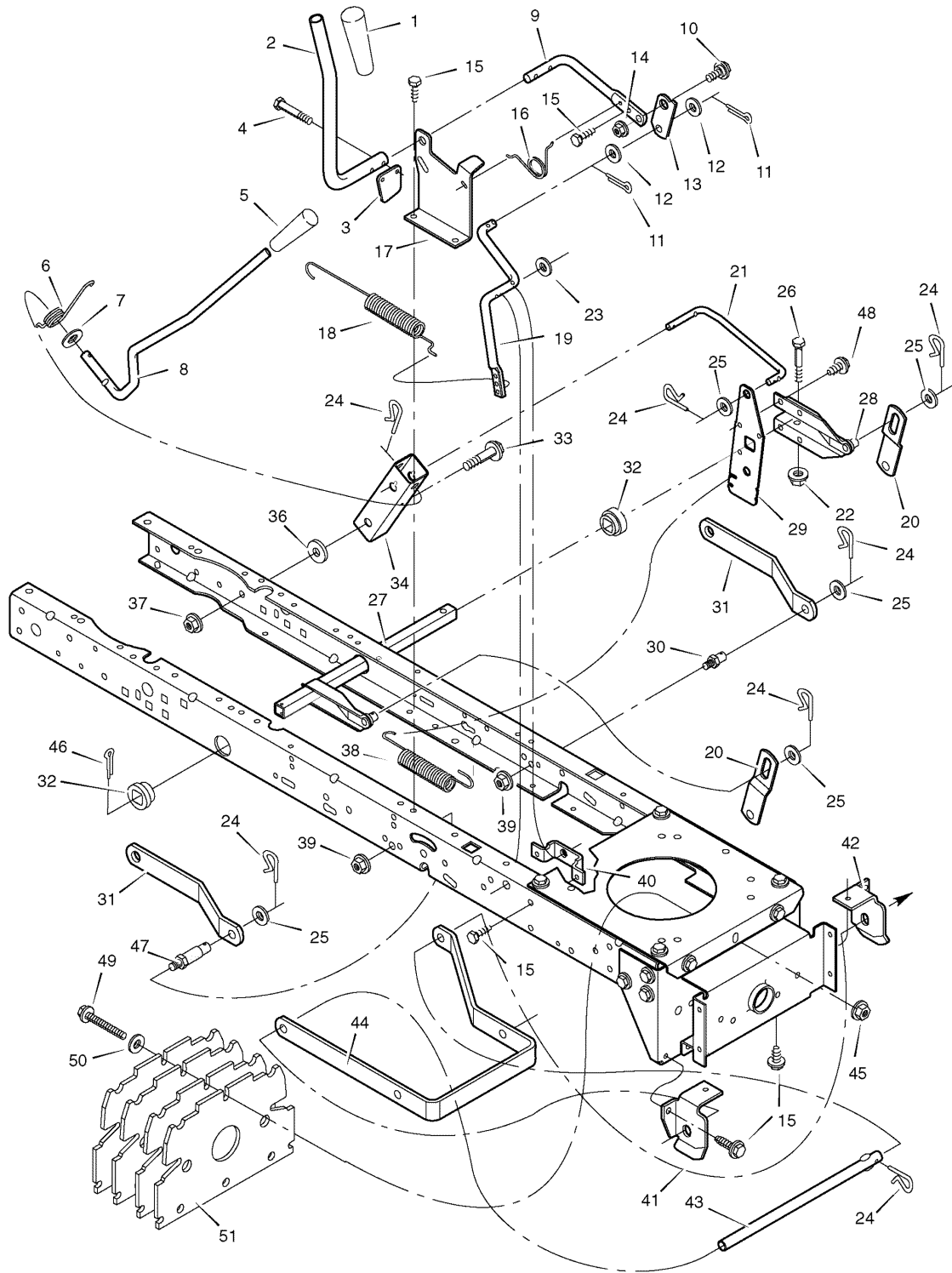

The above parts group applies to the following Mfg. Nos.:
7800523 - 312006x51A

Mower Housing Suspension

REF NO	PART NO.	DESCRIPTION
1	1741757MA	GRIP
2	094157ZMA	HANDLE, PTO
3	094022ZMA	PAD, Switch
4	0025X3MA	SCREW, Hex
5	1741756MA	GRIP
6	166X40MA	SPRING
7	17X103MA	WASHER
8	690533MA	HANDLE, Lift
9	094017ZMA	LEVER, PTO
10	009X39MA	BOLT, Shoulder
11	030X20MA	PIN, Cotter
12	017X57MA	WASHER
13	690277MA	LINK, PTO
14	015X84MA	NUT, Flange
15	26X249MA	SCREW
16	166X39MA	SPRING
17	7300821TMA	BRACKET, PTO
18	165X116MA	SPRING
19	690394E701MA	CRACK, PTO
20	7300791ZMA	LINK, Lift
21	95285MA	LINK, Lift Handle
22	15X118MA	NUT, Flange
23	017X57MA	WASHER
24	0031X4MA	PIN, Hair
25	017X91MA	WASHER
26	001X74MA	BOLT, Hex
27	690386E701MA	ARM ASSEMBLY, Right Lift
28	7400254ZYP	LIFTER TUBE ASSEMBLY
29	7300837ZMA	Plate, Lift Arm
30	094067MA	PIN
31	7300826ZMA	BRACKET, Rear Suspension
32	094065MA	Bushing, Lift Tube
33	009X53MA	BOLT, Shoulder
34	7300819ZMA	BRACKET, Pivot
36	17X191MA	WASHER
37	015X84MA	NUT, Flange
38	165X117MA	SPRING
39	015X68MA	NUT, Flange
40	7300796ZMA	BRACKET, PTO
41	7300861ZMA	HANGER, Right Deck
42	7300860ZMA	HANGER, Left Deck
43	094158ZMA	ROD, Hanger
44	7300784ZMA	HANGER, Front

Footnotes

The above parts group applies to the following Mfg. Nos.:

7800523 - 312006x51A

Mower Housing Suspension

NOTE: Unless noted otherwise,
use the standard hardware torque
specification chart.

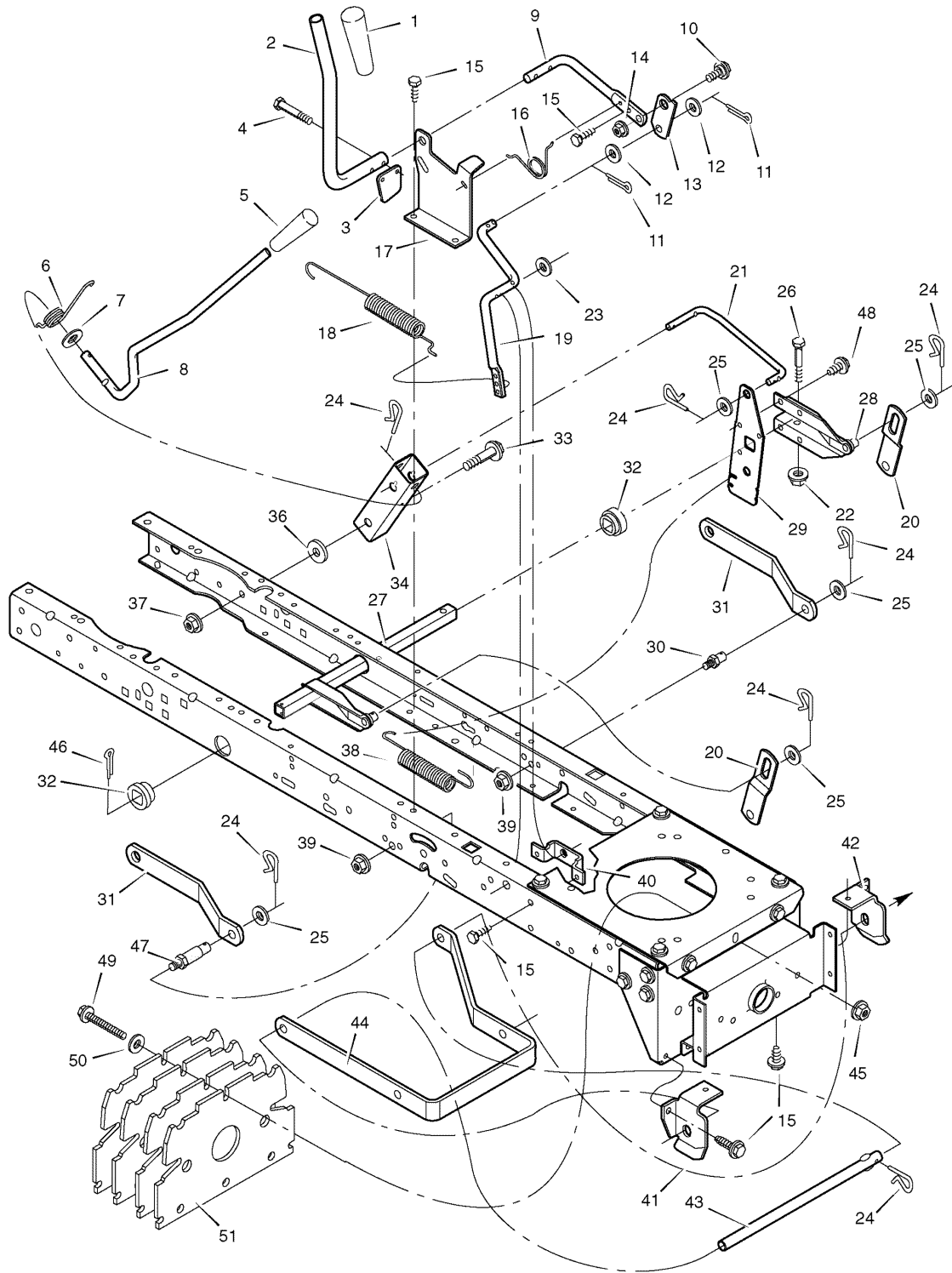

The above parts group applies to the following Mfg. Nos.:
7800523 - 312006x51A

Mower Housing Suspension

REF NO	PART NO.	DESCRIPTION
45	015X89MA	NUT, Flange
46	030X49MA	PIN, Cotter
47	690382MA	PIN, Threaded Shoulder
48	026X49MA	SCREW
49	01X106MA	BOLT, Hex
50	017X38MA	WASHER
51	7300848ZMA	PLATE, Weight (4 Required)

Not for
Reproduction

Footnotes

The above parts group applies to the following Mfg. Nos.:

7800523 - 312006x51A

Decals

NOTE: Unless noted otherwise,
use the standard hardware torque
specification chart.

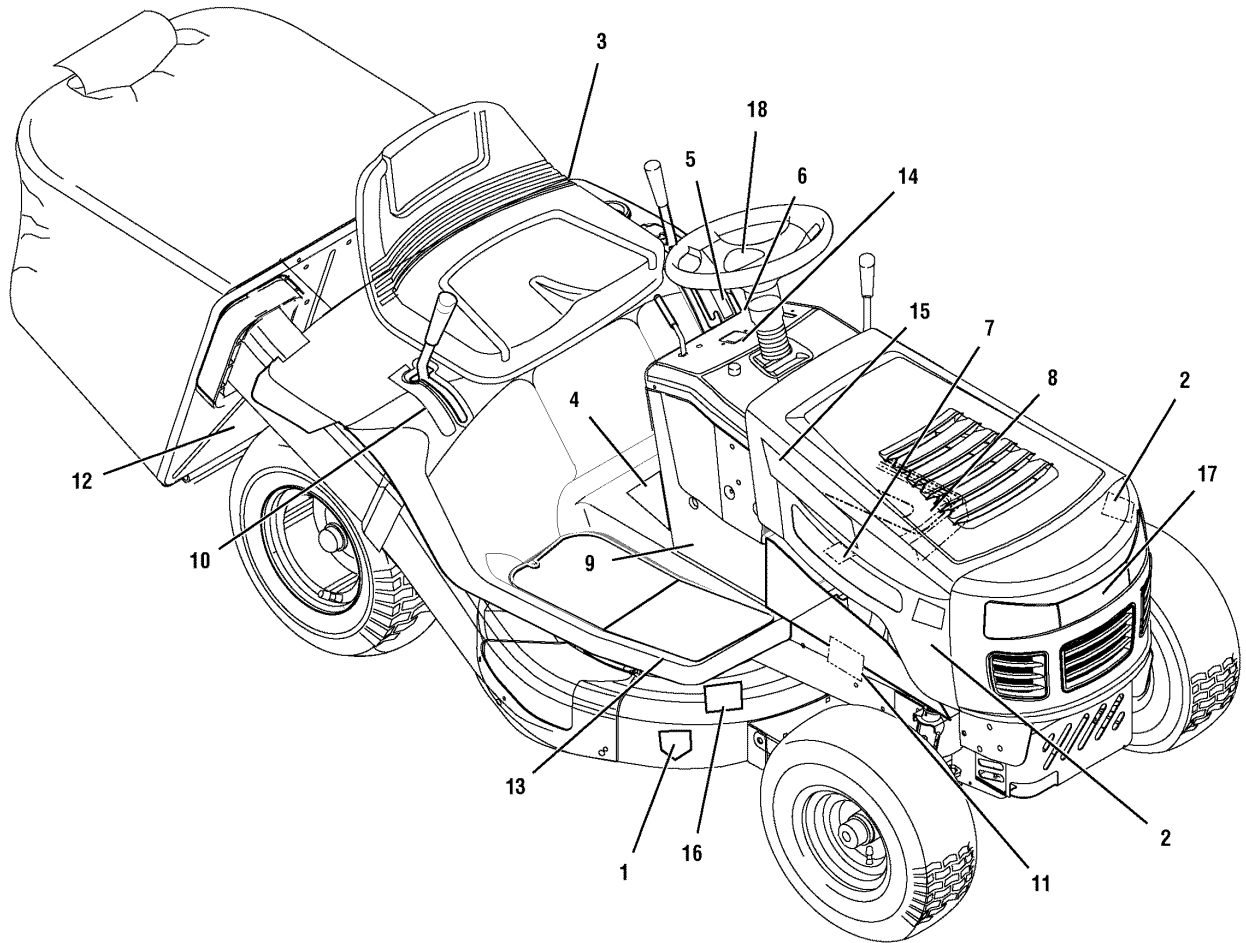

The above parts group applies to the following Mfg. Nos.:

7800523 - 312006x51A

Decals

REF NO	PART NO.	DESCRIPTION
1	885217YP	DECAL, Cut Fingers Signal
2	1742421YP	DECAL, 145/76, Black, Red, White
3	44X6595MA	DECAL, Gas
4	1734027SM	DECAL, Warning Export
5	44X7026MA	DECAL, 7 Position Cut Height
6	44X7027MA	DECAL, Deck Level
7	1742417YP	DECAL, DECK WIDTH 76cm
8	44X5437MA	DECAL, Brake/Clutch Export
9	1742416YP	DECAL, B&S Logo
10	48X5451MA	DECAL, 5 Speed
11	44X5936MA	DECAL, Heat Shield Warning
12	48X511MA	DECAL, Warning Load Limit Export
13	44X6828MA	DECAL, Warning Pinch Point
14	44X6817MA	DECAL, Dash Symbols W1
15	7102772YP	DECAL, MURRAY
16	48X5911MA	DECAL, 100db Export
17	7102288YP	DECAL, Front Hood
18	7102287YP	DECAL, Steering Wheel

Not for
Reproduction

Footnotes

The above parts group applies to the following Mfg. Nos.:

7800523 - 312006x51A

Electrical System

NOTE: Unless noted otherwise, use the standard hardware torque specification chart.

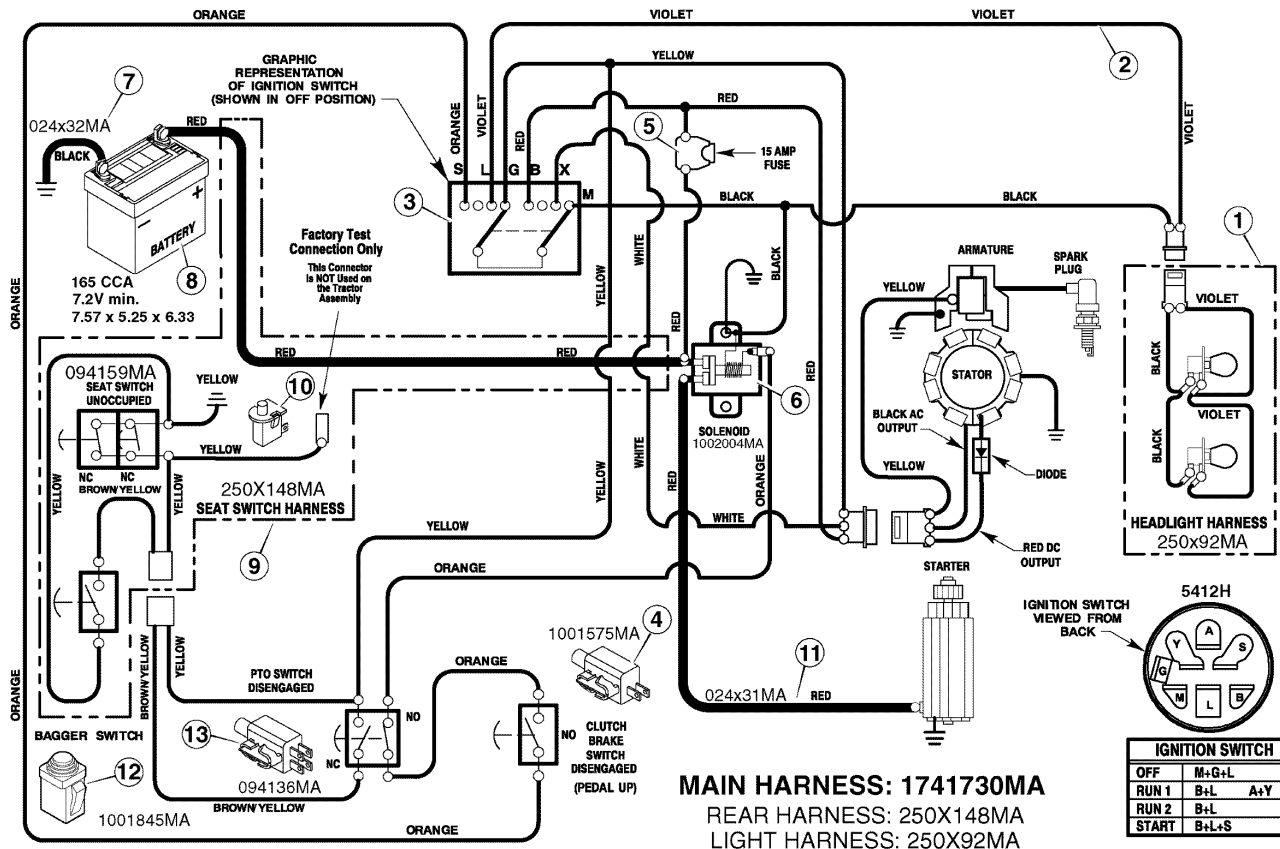

The above parts group applies to the following Mfg. Nos.:

7800523 - 312006x51A

Electrical System

REF NO	PART NO.	DESCRIPTION
1	250X92MA	HARNESS, Light Wire
--	1001716MA	SOCKET, Light
--	090084MA	BULB, Light
2	250X148MA	HARNESS, Chassis Wire
3	5412H	SWITCH, Ignition
--	020729MA	KEY, Ignition
--	091489MA	NUT, Hex
--	091488MA	CAP, Ignition
4	1001575MA	SWITCH, Limit
5	302031MA	FUSE
--	407078MA	HOLDERS, Fuse
6	1002004MA	SOLENOID
--	26X229MA	SCREW, Mounting
--	15X116MA	LOCKNUT
7	024X32MA	CABLE, Battery Ground
--	26X229MA	SCREW, Ground Cable
8	-----	BATTERY 165 CCA 7.2V min. 7.57 x 5.25 x 6.33
--	002X82MA	BOLT, Carriage
--	014X79MA	WINGNUT
--	690604MA	BOOT, Battery Terminal, Positive
9	250X130MA	HARNESS, Seat Switch Wire
10	094159MA	SWITCH, Seat Sensor
11	024X31MA	CABLE
12	1001845MA	SWITCH, Bag Sensor
13	094136MA	SWITCH, Limit

Footnotes

The above parts group applies to the following Mfg. Nos.:

7800523 - 312006x51A

Engine Mount

NOTE: Unless noted otherwise,
use the standard hardware torque
specification chart.

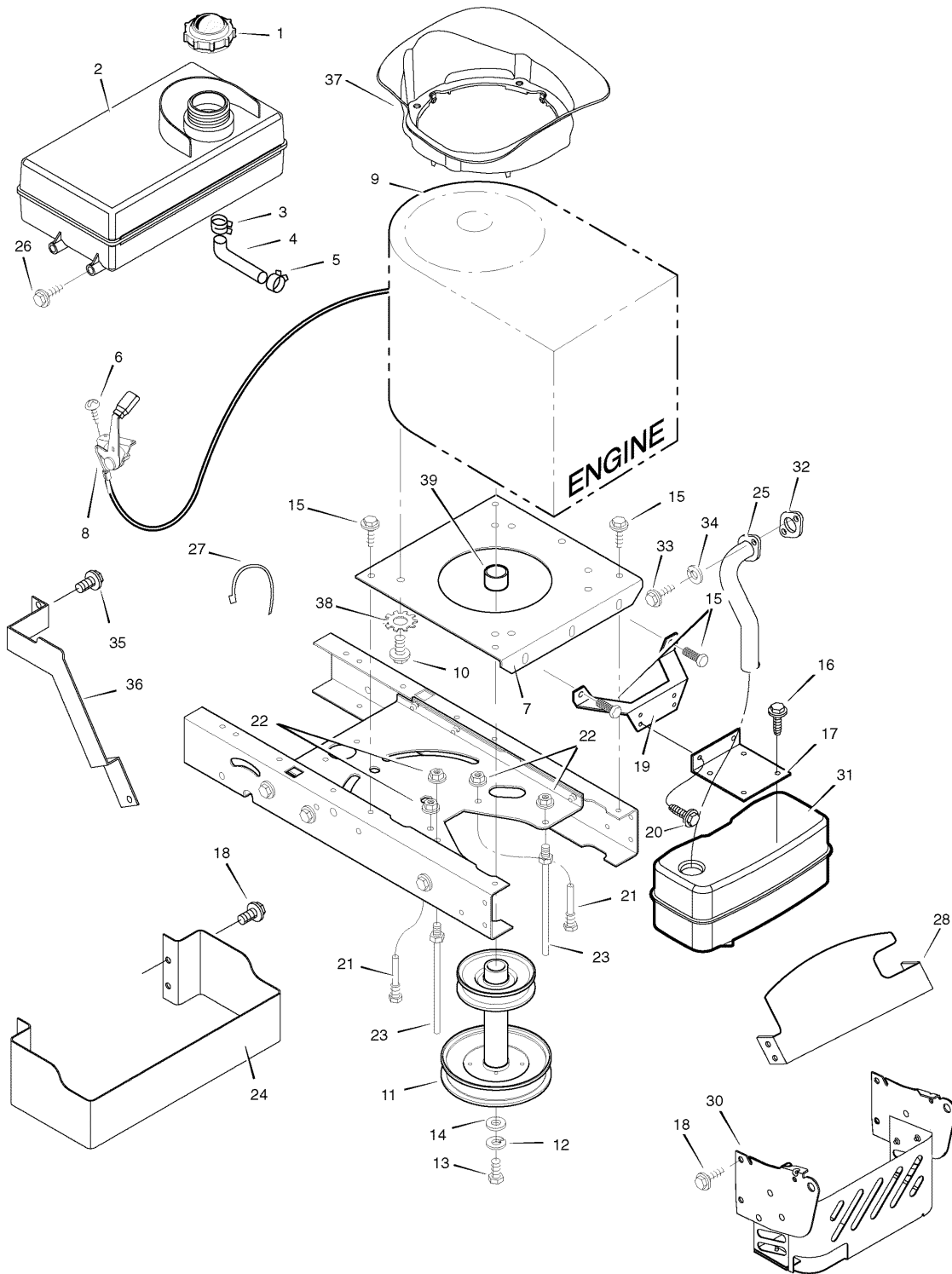

The above parts group applies to the following Mfg. Nos.:
7800523 - 312006x51A

Engine Mount

REF NO	PART NO.	DESCRIPTION
1	092317MA	FUEL CAP (Included with Ref. No. 2)
2	7601092MA	TANK, Fuel 1.4 Gal.
3	095197MA	CLAMP, Hose (Included with Ref. No. 2)
4	7601033MA	FUEL LINE (Must cut to length) (Included with Ref. No. 2)
5	095197MA	CLAMP, Hose (Included with Ref. No. 2)
6	26X201MA	SCREW
7	7300863ZMA	PLATE, Engine
8	092371MA	THROTTLE CONTROL
9	31A507-0123-B1	ENGINE, Briggs & Stratton *
10	0025X7MA	BOLT, Engine Mount
11	690439MA	STACK PULLEY ASSEMBLY
12	019X35MA	LOCKWASHER
13	01X140MA	BOLT, Hex
14	17X170MA	WASHER
15	26X249MA	SCREW
16	26X229MA	SCREW
17	7300760AMA	BRACKET, Muffler
18	26X277MA	SCREW
19	7300817ZMA	BRACKET, Muffler Mount
20	26X213MA	SCREW
21	094384MA	GUIDE, Belt
22	015X79MA	NUT, Flange
23	094066MA	GUIDE, Belt
24	7300783AMA	GUARD, Heat Shield
25	1001496MA	EXHAUST TUBE, Single
26	26X253MA	SCREW
27	032618MA	TIE, Strap, 5.38 Long
28	1740502AMA	GUARD, Heat Shield, Upper
30	7500709AMA	SHIELD, Heat
31	094654MA	MUFFLER
32	692236	GASKET
33	06X103MA	SCREW
34	018X15MA	WASHER
35	06X104MA	BOLT, Washer Hex Head
36	1740504AMA	GUARD, Exhaust Pipe
37	1740503MA	PLENUM, X1 M28/31
38	0019X8MA	WASHER, Star .38 0.68X
39	093077MA	SPACER, Engine

Footnotes

Note* For information on Replacement Parts for this engine contact the manufacturer.

The above parts group applies to the following Mfg. Nos.:

7800523 - 312006x51A

Grass Bagger

NOTE: Unless noted otherwise,
use the standard hardware torque
specification chart.

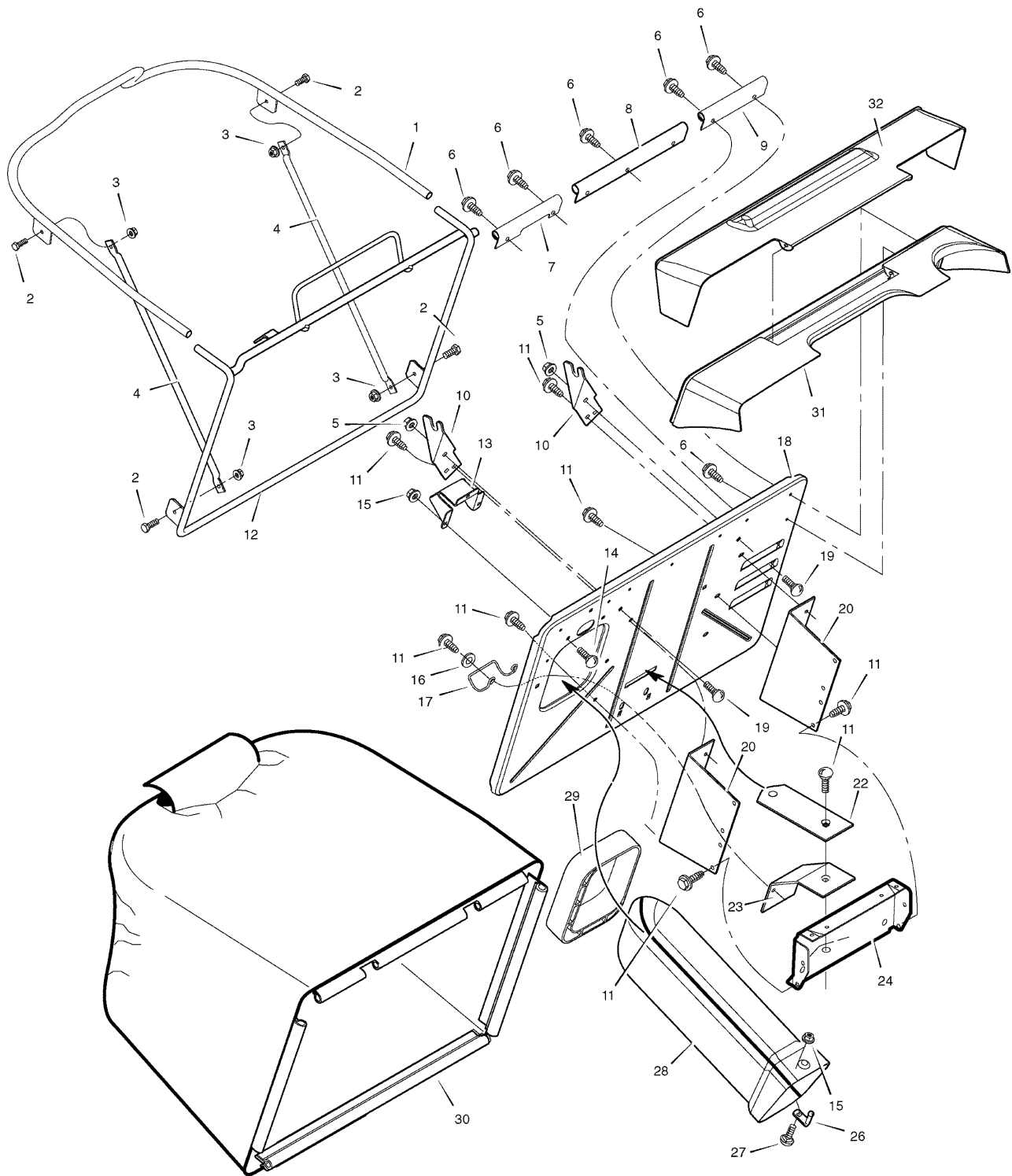

The above parts group applies to the following Mfg. Nos.:
7800523 - 312006x51A

Grass Bagger

REF NO	PART NO.		DESCRIPTION
1	690404MA	1	TUBE, Top
2	01X121MA	4	BOLT
3	15X116MA	4	NUT
4	690433MA	2	STRUT, Bag
5	7090585MA	2	NUT, Flange
6	0193X1MA	9	FASTENER, Panel
7	690491MA	1	SEAL, Bag (Right End)
8	690492MA	1	SEAL, Bag (Center)
9	690493MA	1	SEAL, Bag (Left End)
10	7300785ZMA	2	HINGE
11	26X249MA	6	SCREW
12	885167YP	1	ASSEMBLY, Bag Frame
13	7300768ZMA	1	BRACKET, Switch
14	002X82MA	3	BOLT, Carriage
15	015X89MA	1	NUT, Flange
16	17X185MA	2	WASHER
17	690402MA	1	LATCH, Spring
18	885165YP	1	PANEL, Rear
19	002X53MA	2	BOLT, Carriage
20	7300731ZMA	2	BRACKET, Bagger Mounting
22	7300835ZMA	1	PLATE, Hitch
23	7300757ZMA	1	BRACKET, Lower Mounting
24	7300864ZMA	1	PLATE, Hitch
26	054563MA	1	PIN, Latch
27	002X39MA	1	BOLT, Carriage
28	690368MA	1	TUBE, Connecting
29	690429MA	1	GROMMET, Extension Tube
30	690438MA	1	BAG, Grass
31	885163YP	1	BAGGER COVER, Front
32	885164YP	1	BAGGER COVER, Rear

Footnotes

The above parts group applies to the following Mfg. Nos.:

7800523 - 312006x51A

Not for
Reproduction

Not for
Reproduction

Not for
Reproduction

Hardware Identification & Torque Specifications

Common Hardware Types

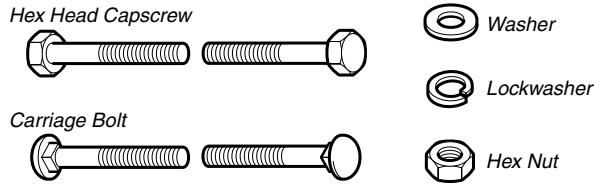

Standard Hardware Sizing

When a washer or nut is identified as 1/2", this is the *Nominal size*, meaning the *inside diameter* is 1/2 inch; if a second number is present it represents the *threads per inch*

When bolt or capscrew is identified as 1/2 - 16 x 2", this means the *Nominal size*, or *body diameter* is 1/2 inch; the second number represents the *threads per inch* (16 in this example, and the final number is the *body length* of the bolt or screw (in this example 2 inches long).

The guides and ruler furnished below are designed to help you select the appropriate hardware and tools.

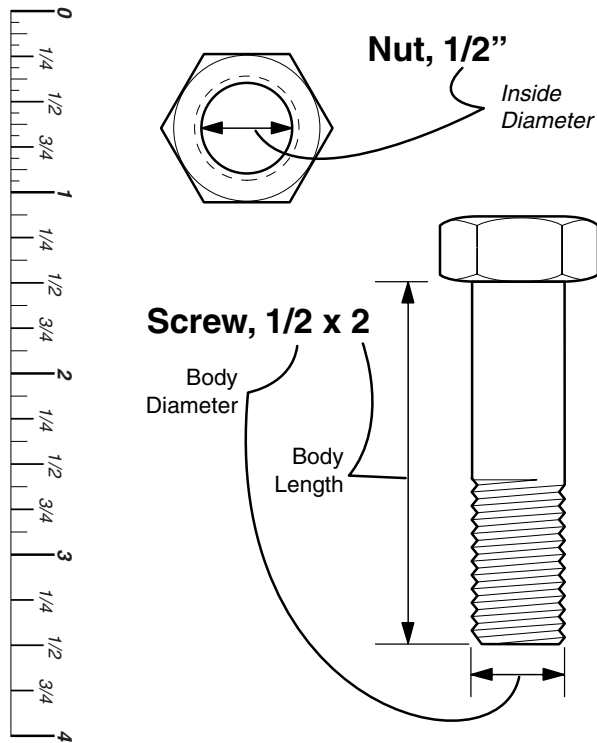

Torque Specification Chart

FOR STANDARD MACHINE HARDWARE (Tolerance ± 20%)

Hardware Grade	No Marks SAE Grade 2		SAE Grade 5		SAE Grade 8	
	in/lbs ft/lbs	Nm.	in/lbs ft/lbs	Nm.	in/lbs ft/lbs	Nm.
8-32	19	2.1	30	3.4	41	4.6
8-36	20	2.3	31	3.5	43	4.9
10-24	27	3.1	43	4.9	60	6.8
10-32	31	3.5	49	5.5	68	7.7
1/4-20	66	7.6	8	10.9	12	16.3
1/4-28	76	8.6	10	13.6	14	19.0
5/16-18	11	15.0	17	23.1	25	34.0
5/16-24	12	16.3	19	25.8	27	34.0
3/8-16	20	27.2	30	40.8	45	61.2
3/8-24	23	31.3	35	47.6	50	68.0
7/16-14	30	40.8	50	68.0	70	95.2
7/16-20	35	47.6	55	74.8	80	108.8
1/2-13	50	68.0	75	102.0	110	149.6
1/2-20	55	74.8	90	122.4	120	163.2
9/16-12	65	88.4	110	149.6	150	204.0
9/16-18	75	102.0	120	163.2	170	231.2
5/8-11	90	122.4	150	204.0	220	299.2
5/8-18	100	136	180	244.8	240	326.4
3/4-10	160	217.6	260	353.6	386	525.0
3/4-16	180	244.8	300	408.0	420	571.2
7/8-9	140	190.4	400	544.0	600	816.0
7/8-14	155	210.8	440	598.4	660	897.6
1-8	220	299.2	580	788.8	900	1,244.0
1-12	240	326.4	640	870.4	1,000	1,360.0

NOTES

- These torque values are to be used for all hardware excluding: locknuts, self-tapping screws, thread forming screws, sheet metal screws and socket head setscrews.
- Recommended seating torque values for locknuts:
 - for prevailing torque locknuts - use 65% of grade 5 torques.
 - for flange whizlock nuts and screws - use 135% of grade 5 torques.
- Unless otherwise noted on assembly drawings, all torque values must meet this specification.

Wrench & Fastener Size Guide



1/4" Bolt or Nut
Wrench—7/16"

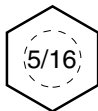

5/16" Bolt or Nut
Wrench—1/2"

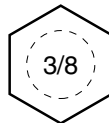

3/8" Bolt or Nut
Wrench—9/16"



7/16" Bolt or Nut
Wrench (Bolt)—5/8"
Wrench (Nut)—11/16"

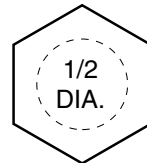

1/2" Bolt or Nut
Wrench—3/4"

Not for
Reproduction